

Display Board GAZ4



ALGE
TIMING
ELECTRONIC DEVICES

English

- 1 Thumb wheel switch
- 2 Data input (banana plug yellow and black)
- 3 Toggle switch: (for setup of **ALGE** format)
- 4 AC fuse (2 x T0,5A/220V) **
- 5 Charger control lamp **
- 6 Battery fuse (T2A/220V) *
- 7 On-/Off switch *
- 8 Battery control (green = good, red = poor) *
- 9 Power cable connection (220 V / 50 Hz) **
- 10 Amphenol plugs (hinged, both sides)
- 11 Typeplate

* Only at GAZ4 with buit in powerpack PP4

** Only at GAZ4 with buit in powerpack PP4 or power supply PS4

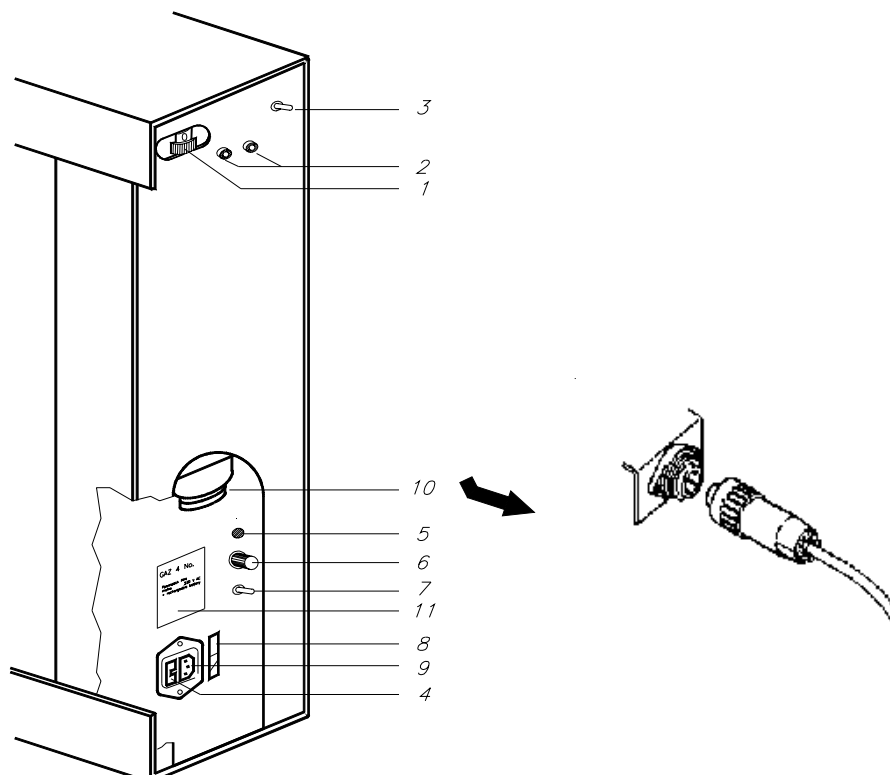

TABLE OF CONTENTS

1. GENERAL	4
2. POWER SUPPLY	5
2.1. Powerpack PP4	5
2.2. Powersupply PS4	5
2.3. External Battery	5
2.4. Connection of two ALGE Display Boards	6
3. OPERATIONAL-MODES AND SWITCH POSITIONS	7
3.1. Operation-Modes	7
3.2. Switch Positions	7
3.2.1. Toggle-Switch (3)	7
3.2.2. Thumb-Wheel-Switch (1)	8
3.3. Shift Output Format	9
4. NORMAL OPERATION OF THE GAZ4	11
4.1. Display Board GAZ4 controlled by the ALGE TdC 8000	12
4.2. Display Board GAZ4 controlled by the ALGE Timer S4	13
4.3. Display Board GAZ4 controlled by a ALGE Comet	14
5. CLOCK 13	13
5.1. Clock started from 0:00.00	15
5.2. Set the Clock	15
6. COUNT DOWN WITH TIME-OUT	16
7. TECHNICAL DATA	17
7.1. Electronic	17
7.2. Display Modules	17
7.3. Casing	17
7.4. Time Basis	17
7.5. Power Consumption	17
7.6. Connections	18
7.7. Switches	18
7.8. Fuses	19
7.9. Power Supply	19
7.10. Temperature Range	19
7.11. Dimensions and Weight	19
7.12. Interface	20
8. DISPLAY FORMATS OF THE GAZ4	22
9. RANKING (LEADER) BOARD	24

1. GENERAL

The ALGE GAZ4 display-board is the fourth in a series made with modern technology (CMOS, microprocessor, watchdog).

Reliable 7-segment modules are mounted inside a plexiglass covered aluminium case. This modules are available in heights of 15, 25, and 45 cm (6, 10, and 18 inch). The digits are very visible even in direct sunlight.

The power requirements of the boards are quite low due to our advanced engineering. The optional rechargeable powerpack allows effective use with the ease of a on board battery.

ALGE display boards are available with several different options. They can be used for display of time, weight, price, speed, temperature, etc.

The GAZ4 display board is primarily used with the ALGE timing devices for spectator information.

Please read the manual carefully, so that you will be able to learn all of the features of the ALGE GAZ4 prior to use. Keep the manual handy so that you can refer to it as needed. If you get really confused, give us a call.

2. POWER SUPPLY

We deliver the display board GAZ4 with different power supply possibilities:

2.1. Powerpack PP4:

The powerpack is built into the GAZ4, if ordered that way. The powerpack has NiCad batteries (12 V, 2 Ah), and charger unit (220 V or 110 V, see label) with overcharge protection. Direct supply from the charger is possible, that means it is possible to use a board even with empty batteries.

Recharging the NiCad batteries:

- Switch GAZ4 with toggle switch (7) off.
- Plug computer style power cable into the right side of the GAZ4 (9).
- Charger control lamp (5) is on.
- It takes at about 14 hours to recharge the batteries (overcharge protection).

Working time with completely recharged batteries as independent clock:

GAZ with 15 cm digit height: at about 40 hours
GAZ with 25 cm digit height: at about 20 hours
GAZ with 45 cm digit height: at about 10 hours

The operational time gets shorter during cold weather (e.g. for - 20 degrees Celsius about 20%).

END:

If the display shows „End“, it means that the battery voltage is too low. The microprocessor turns off, and you have to plug it to the AC outlet. As soon as you plug the GAZ4 to the AC outlet it resets the GAZ4 automatically and it starts to work again. Previous adjustments (e.g. like refresh) are stored and continue to work.

You can also plug in a car battery with the same procedure using the battery cable. Do not use both at the same time.

2.2. Powersupply PS4:

Built in power supply for direct AC with 110 or 220 V (see label), if ordered that way. You can power up to two display boards (connect them with cable 033-01).

2.3. External Battery:

A 12 Volt battery (car battery) with a minimum of 2 Ah is connected to the display board with the power cable. It is important that you check the polarity of the clips [connect (+) with (+) and (-) with (-)].

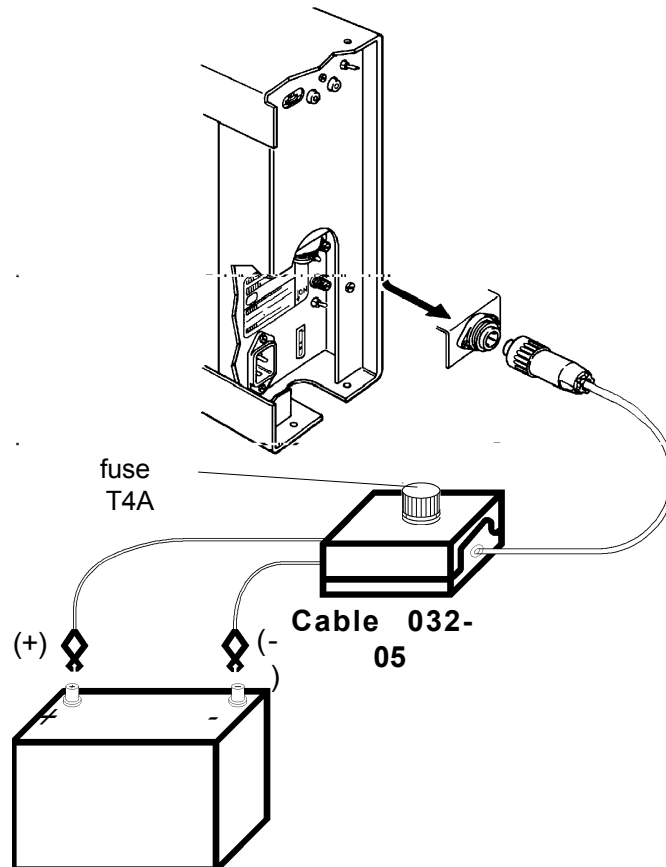

2.4. Connection of two ALGE Display Boards:

If you connect two GAZ4 together (e.g. start number/rank board and time board) you only need a Powerpack PP4 or Powersupply PS4 in one GAZ4, or a battery. For the connection you need the ALGE cable 033-01

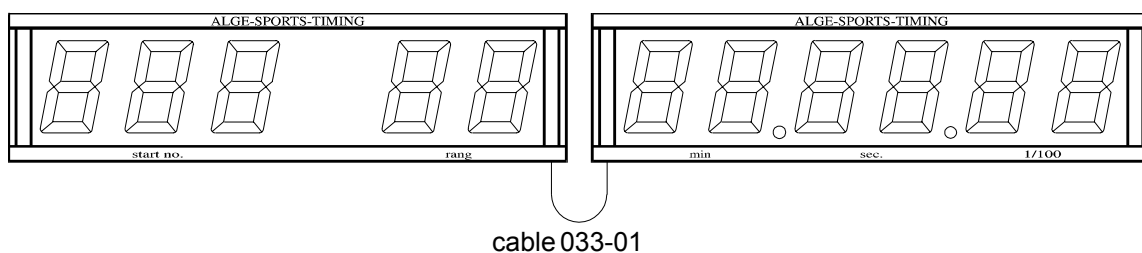

3. OPERATIONAL-MODES AND SWITCH POSITIONS

3.1. Operation-Modes:

The GAZ4 works either with ALGE timing devices or as a stand alone independent display.

The GAZ4 receives data from:

- ALGE TdC 4000
- ALGE Timer S4
- ALGE Comet
- Computer, RS232, 2400 baud N,1,8
- ALGE Videotimer VT2
- ALGE Timer S3
- ALGE OPTI 1sw

Independent Display Clock:

- Clock starting at 0:00.00
- Clock starting at a preset time
- Count-Down with time-out

3.2. Switch Positions:

3.2.1. Toggle-switch (3):

The shift toggle switch (3) controls the digit format. The data information given below is for a 6 digit standard display board.



Toggle switch up:

- Thumb wheel switch (1) on 0: shows start number (3-digit) and rank (2-digit), when connected to TdC 4000.
- Thumb wheel switch (1) on 13: shows the start number (3-digit) and hours (2-digit) when connected with TdC 4000.



Toggle switch in middle position:

- Thumb wheel switch (1) on 0: Shows time in minutes, seconds, and 1/100 sec.
- Thumb wheel switch (1) on 13: shows the time in minute (one digit), seconds, and 1/1000 sec.



Toggle switch down:

- Thumb wheel switch (1) on 0: shows time in hours, minutes and seconds.
- Thumb wheel switch (1) on 13: shows the time hours (one digit), minutes, seconds, and 1/10 sec.

3.2.2. Thumb-wheel-switch(1):

The thumb-wheel-switch (1) has 16 positions. The GAZ4 works normally from position 0 to 13, and as a independent clock in position 14 (countdown) and 15 (clock).

- 0 standard
- 1 - 10 GAZ address
- 11 test
- 12 refresh
- 13 shift
- 14 count down
- 15 clock

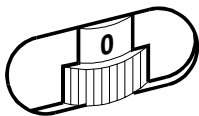

STANDARD 0

The GAZ4 works on position 0 as data receiver from the ALGE TdC 4000, Timer S3 or Comet Commander.

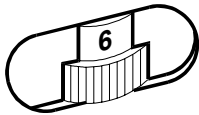

GAZ ADDRESS 1 - 10

Position 1 to 10 are used to address the GAZ4 (e.g. ranking board, Self-Timer SF2, speed skating)

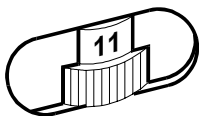

TEST 11

Position 11 has a program to test all the digits. Different test programs can be set with the toggle switch (3).



Test Thumbwheelswitch and data input
DL ... low (shortcuted)
DH... high (open)

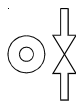

digit by digit is counting up from 1 to 0



all digits are changing from 8 to blank and from blank to 8.



REFRESH 12

In position 12 you turn the refresh on. The refresh updates all of the digits every ten seconds. You need the refresh e.g. when you use the GAZ4 on top of a car. It could happen through bumps, that a segment of a digit flips back and a number would be written wrong. After you turn it on refresh mode the GAZ4 shows on the display „r on“. Now switch the thumb-wheel-switch to the position you need for timing.

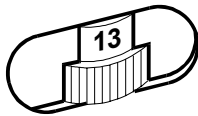
**SHIFT 13**

Position 13 shifts the output format one position to the left. The other functions are like on position 0. If you want to show 1/10 and 1/1000 sec. the shift position is needed (e.g. cross country skiing, car racing, speed skating, bobsled, etc..)

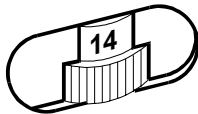
**COUNT DOWN 14**

Position 14 is the countdown mode (see page 14, point 6).

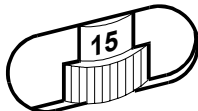
**CLOCK 15**

Position 15 is the independent clock (see page 15, point 5).

3.3. Shift Output Format:

It is possible to shift the entire display one position to the left. You have to turn the thumb-wheel-switch (1) to position 13. This allows you to show the 10's when you are displaying Hours, Min., Seconds or the 1000's when you are displaying Min., Sec 100's. (e.g. for cross country skiing, car racing, bobsled, speed skating).

Digit 6	Digit 5	Digit 4	Digit 3	Digit 2	Digit 1	Position of Shift-Switch	Position of Thumb-Wheel-Switch
Nh	Nz	Ne		Rz	Re	up	0
M	M	S	S	z	h	middle	0
H	H	M	M	S	S	down	0
Nh	Nz	Ne		H	H	up	13
M	S	S	z	h	t	middle	13
H	M	M	S	S	z	down	13

Nh startnumber (hundred digit)
 Nz startnumber (ten digit)
 Ne startnumber (one digit)
 Rz rank (ten digit)
 Re rank (one digit)
 H hours
 M minutes
 S seconds
 z 1/10 sec.
 h 1/100 sec.
 t 1/1000 sec.

4. NORMAL OPERATION OF THE GAZ4

The display-board GAZ4 receives data from other devices like ALGE TdC 4000, ALGE Timer S4, ALGE Videotimer VT2, ALGE Comet, etc.

It is possible to change the input format of the GAZ4, because different devices send different data.

SHIFT-TOGGLE SWITCH (3):

The shift toggle switch (3) controls the digit format. The data information given below is for a 6 digit standard display board.

Toggle switch up:



- Thumb wheel switch (1) on 0: shows startnumber (3-digit) and rank (2-digit), when connected to TdC 4000.
- Thumb wheel switch (1) on 13: shows the startnumber (3-digit) and hours (2-digit) when connected with TdC 4000.

Toggle switch in middle position:



- Thumb wheel switch (1) on 0: Shows time in minutes, seconds, and 1/100 sec.
- Thumb wheel switch (1) on 13: shows the time in minute (one digit), seconds, and 1/1000 sec.

Toggle switch down:



- Thumb wheel switch (1) on 0: shows time in hours, minutes and seconds.
- Thumb wheel switch (1) on 13: shows the time hours (one digit), minutes, seconds, and 1/10 sec.

4.1. Display Board GAZ4 controlled by the ALGE TdC 8000:

The same instructions are valid for the TdC 4000 as for the TdC 8000.

- Connect the data cable 010-10 with the TdC 8000 and GAZ4 (2)
Attention: be careful to connect the yellow banana plug with the yellow banana socket and black banana plug with the black banana socket.
- Rotate thumb-wheel-switch (1) to position „0“ or „13“
- Set toggle switch (3) to the format position you need (see page 9 point 4.)

startnumber / rank up
 minutes, seconds, 1/100 sec. (1/1000 sec.) middle
 hours, minutes, seconds (1/10 sec.) down

- Power supply:

If the GAZ4 has a built in powerpack turn switch (7) on

If the GAZ4 has no powerpack connect it with e.g. an external 12 V battery (see chapter 2)

- The GAZ4 shows the program version and then the word ALGE signalling that it is ready to receive data
- When you turn the TdC 8000 on, the display goes „blank“
- Set the program in TdC 8000 and start your timing. When the display of the TdC 8000 shows a running time, it shows either the running time or the startnumber and rank on the GAZ4 (otherwise turn the plug of the cable 010-10 on the back side of the Timer 180 degrees).

Turn the plug 180° to
 switch
 from run time to
 running time

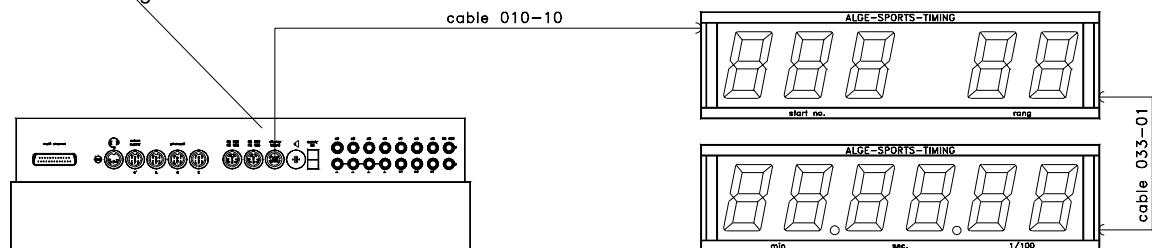

You can use also a banana-plug cable between display board and TdC 8000. Then plug the cable (e.g. 000-10) at the banana socket of the TdC 8000 in the very right.

4.2. Display Board GAZ4 controlled by the ALGE Timer S4:

- Connect data cable 010-10 with the Timer S4 and GAZ4 (2).
Attention: be careful to connect the yellow banana plug with the yellow banana socket and black banana plug with the black banana socket.
- Rotate thumb-wheel-switch (1) to position „0“ or "13"
- Set toggle switch (3) to the format position you need (see page 9)
 - minutes, seconds, 1/100 sec. (1/1000 sec.) middle
 - hours, minutes, seconds (1/10 sec.) down
- Power supply:
 - If the GAZ4 has a built in powerpack turn switch (7) on
 - If the GAZ4 has no powerpack connect it with e.g. an external 12 V battery (see chapter 2)
- The GAZ4 shows the program version and with ALGE that it is ready to receive data
- When you turn the Timer S4 on, the display turns on „blank“
- When the display of the Timer S4 shows a running time, it shows the running time on the GAZ4 (otherwise turn the plug of the cable 010-10 on the back side of the Timer 180 degrees)

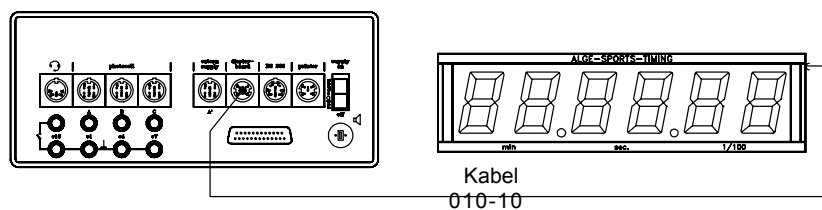

You can extend the cable 010-10 from the Timer S4 to the display board GAZ4 up to 1 km. As extension use e.g. ALGE cable reel KT300 or KT 500.

4.3. Display Board GAZ4 controlled by a Comet:

- Connect data cable 030-10 or 060-10 with the Comet and GAZ4 (2).
- Rotate thumb wheel switch (1) to position „0“.
- Set toggle switch (3) on middle position (minutes, seconds, 1/100) or lower position (hours, minutes, seconds)
- Power supply:
 - If the GAZ4 has a built in powerpack turn switch (7) on.
 - If the GAZ4 has no powerpack connect it with e.g. an external 12 V battery (see chapter 2).
- The GAZ4 shows the program version and with ALGE that it is ready to receive data.
- Turn the Comet on (program Commander), and start to operate.

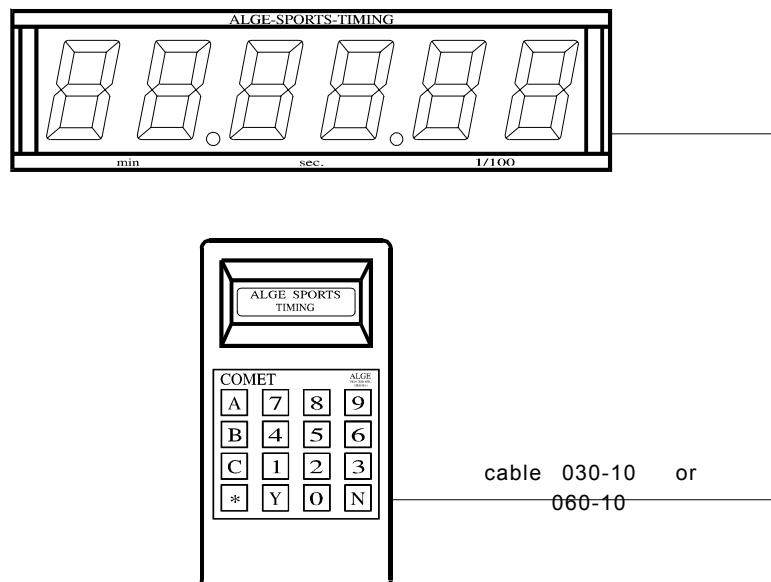

Cable 030-10 is a cable with 3 wires, also including power supply from the display board to the Comet.

Cable 060-10 is a cable with 2 wires (data and ground). If you need to transmit the data over a long distance you can use the cable reel KT300 (300 m) or KT500 (500 m) as extension.

5. CLOCK

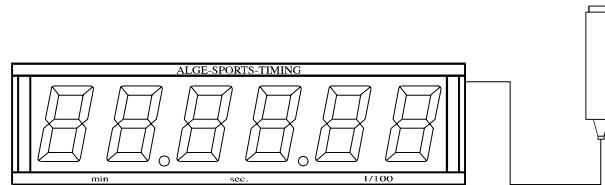

5.1. Clock starting from 0:00.00

- Rotate thumb-wheel-switch (1) to position „15“
- Set toggle switch (3) on middle position (minutes, seconds, 1/100) or lower position (hours, minutes, seconds)
- Plug handswitch 023-02 into the data input banana sockets (2)
- Power supply:
 - If the GAZ4 has a built in powerpack turn switch (7) on
 - If the GAZ4 has no powerpack connect it with e.g. an external 12 V battery (see chapter 2)
- Wait until the GAZ4 shows 0:00.00
- Press handswitch to start the clock
- Press handswitch again and the clock stops
- When you press the handswitch the clock runs again (the stop impulse before was an intermediate time)
- Reset the clock to 0:00.00 by pressing the handswitch for 5 seconds until the GAZ4 shows ALGE

5.2. Set the Clock:

- Rotate thumb-wheel-switch (1) to position „15“.
- Set toggle switch (3) on middle position (minutes, seconds, 1/100) or lower position (hours, minutes, seconds)
- Plug handswitch 023-02 into the data input banana sockets (2)
- Power supply:
 - If the GAZ4 has a built in powerpack turn switch (7) on
 - If the GAZ4 has no powerpack connect it with e.g. an external 12 V battery (see chapter 2)
- Wait till the GAZ4 shows 0:00.00
- Press the handswitch till the GAZ4 shows a number on it's left hand digit. You can increase this position in one digit increments by pressing once for each change. (hours, minutes, seconds)
If you make a mistake hold the switch down for 5 seconds until it resets to all zeros, continue holding until it moves to the first digit again.
- When you reach the desired number, keep the handswitch pressed, till it shows the next two figures. Make sure that you do not press more than is necessary or it will go one to many and you will have to reset it. Now you may set these digits like the one before.
- Continue until the clock is set (all figures are shown on the display).
- Press the handswitch to start the clock.
- Press the handswitch again to stop the clock.
- When you press the handswitch once more the clock runs again (the stop impulse before was an intermediate time).
- Reset the clock by pressing the handswitch until GAZ4 shows ALGE. If you want to set the clock again, or have made a mistake.

6. COUNTDON WITH TIME-OUT

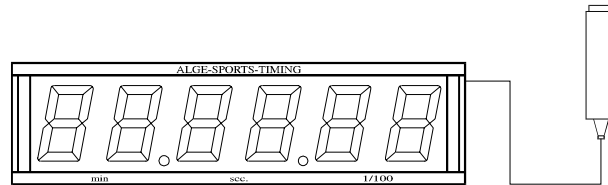

The countdown is possible from 99 hours, 59 minutes, 59 seconds.

- Rotate thumb-wheel-switch (1) to position „14“
- Set toggle switch (3) on middle position (minutes, seconds, 1/100) or lower position (hours, minutes, seconds)
- Plug handswitch 023-02 into the data input banana sockets (2)
- Power supply:
 - If the GAZ4 has a built in powerpack turn switch (7) on
 - If the GAZ4 has no powerpack connect it with e.g. an external 12 V battery (see chapter 2)
- Wait till the GAZ4 shows 0:00.00
- Press the handswitch till the GAZ4 shows a figure on its first digit. Now you can set this position through pressing the handswitch (hours, minutes, or seconds)
- When you reached the wanted figure keep the handswitch pressed, till it shows the next two figures. Now set this figures like the one before.
- Continue till the countdown is set (all figures are shown on the display)
- Press the handswitch to start the countdown
- Press the handswitch again to stop the countdown
- When you press the handswitch once more the clock continues the countdown (the stop impulse before was time-out)
- If the countdown reaches 0:00.00 it stops for three seconds, then the clock goes back to the countdown time you set before
- You can start the next countdown through pressing the handswitch
- If you want to reset the countdown before it reaches zero, press the handswitch till the GAZ4 shows ALGE

7. TECHNICAL DATA

7.1. Electronic:

Modern microprocessor technology (80C31) with CMOS technic.

7.2. Display Modules:

Bi-stable electromagnetic 7-segment modules, phosphorescent yellow segments, black casing, low power consumption, high visibility, best reliability.

7.3. Casing:

Plastic-covered aluminium casing (black) for outdoor use.

7.4. Time Basis: Quartzoszillator with 9.2160 MHz.

7.5. Power Consumption:

Stand by Current: 10 mA

Max. consumption during position change (every second if clock runs)

figure hight	max. current	impulse time
150 mm	123 mA	120 ms
250 mm	360 mA	120 ms
450 mm	360 mA	150 ms

7.6. Connections:

- Two Amphenol plugs (one on each side)

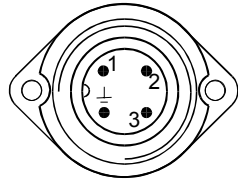

- 1 +11 to 20 Volts
- 2 0 Volt
- 3 no connection
- E Data

- Two banana jacks:
 - o data line (RXD+) yellow
 - o ground (RXD-) black
- Computer style plug (220 VAC or 110 VAC) to charge the built in powerpack PP4 or supply the display board direct from the mains (Powersupply PS4).

7.7. Switches:

- On/Off switch (when GAZ4 with built in powerpack).
- Shift-toggle switch (3):

The shift toggle switch (3) controls the digit format. The data information given below is for a 6 digit standard display board.

Toggle switch up:



- Thumb wheel switch (1) on 0: shows startnumber (3-digit) and rank (2-digit), when connected to TdC 4000.
- Thumb wheel switch (1) on 13: shows the startnumber (3-digit) and hours (2-digit) when connected with TdC 4000.

Toggle switch in middle position:

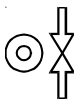

- Thumb wheel switch (1) on 0: Shows time in minutes, seconds, and 1/100 sec.
- Thumb wheel switch (1) on 13: shows the time in minute (one digit), seconds, and 1/1000 sec.

Toggle switch down:



- Thumb wheel switch (1) on 0: shows time in hours, minutes and seconds.
- Thumb wheel switch (1) on 13: shows the time hours (one digit), minutes, seconds, and 1/10 sec.

7.8. Fuses: 2 x T 0.5 A / 230 V or 2 x T1A / 115 V ACfuse
 1 x T 2 A / 110/220 V battery fuse

Small European style fuse available at Radio Shack

7.9. Power Supply:

- external 11 to 20 VDC, 2 A
- additional with build in powerpack (rechargeable batteries with charger and overcharge protection for net supply).
 - Rechargeable batteries:* NiCad batteries
 - Capacity:* 2 Ah / 12 V
 - Time to recharge:* 14 hours
 - Working time:* about 20 hours (25 cm digit)
 - Recharge connection:* 220 V or 110 V (over charge protection)
- additional with build in powersupply
 - Power connection:* 220 V or 110 V

7.10. Temperature Range: -25 to 50°C

7.11. Dimensions and Weight:

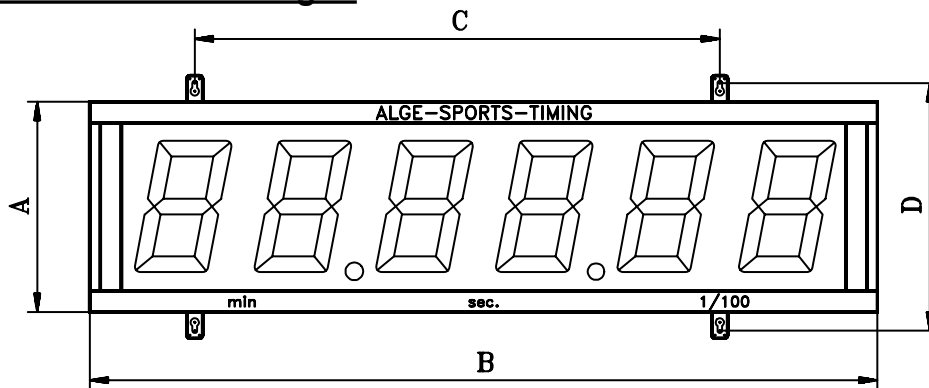

standard types	kg	A (mm)	B (mm)	C (mm)	D (mm)	depht (mm)	visibility ca. m	operating time ca. h *
GAZ4 515	12	290	956	556	352	100	75	60
GAZ4 615	13	290	956	556	352	100	75	60
GAZ4 525	20	393	1493	1093	455	100	125	20
GAZ4 625	21	393	1493	1093	455	100	125	20
GAZ4 545	45	664	2490	2090	726	120	225	11
GAZ4 645	48	664	2490	2090	726	120	225	11

* at low temperatures you have a shorter operation time (-20°C about less 20%)

7.12. Interface:

Serial Interface:

Signal compatible to RS 232 C interface, serial, no handshake.

Transfer format:

2400 Baud
1 Start bit
8 Data ASCII-Bit
1 Stop bit
no Parity bit

Data format:

On the next page you can see the data format of different ALGE timers.

J code for ranking board from A to J (A = board 1, B = board 2, ..., J = board 10)
Nt start number (thousand)
Nh ... start number (hundred)
Nz start number (ten)
Ne ... start number (single)
H hours
M minutes
S seconds
z 1/10 seconds
h 1/100 seconds
t 1/1000 seconds
Rz rank (ten)
Re ... rank (single)
X carriage return (0D Hex.) or line feed (0A Hex.) and carriage return (0D Hex.)
. identification for running Time if point is on 4th position
A TdC 4000: identification for intermediate time 1 (on 4th position)
B TdC 4000: identification for intermediate time 2 (on 4th position)
C TdC 4000: identification for run time (on 4th position)
D TdC 4000: identification for total time (on 4th position)
K Comet: 1 = start channel, 2 = start channel, 4 = stop channel, 8 stop channel
Tc Comet: Timer identification: Timer A or B
Tt Timer S4: Timer identification: A, B, or C Timer
Pr Timer S4 show jumping: parcours (ASCII P)
PZ ... Timer S4 show jumping: penalty points (ten)
PE ... Timer S4 show jumping: penalty points (single)
Pz Timer S4 show jumping: penalty points (1/10)
Ph Timer S4 show jumping: penalty points (1/100)
#h Timer S4 18-channel-timer: continues number (hundred)
#z Timer S4 18-channel-timer: continuous number (ten)
#e Timer S4 18-channel-timer: continuous number (single)
Pp Timer S4 parallel slalom: parcours (ASCII P)
r Timer S4 parallel slalom: identification for red parcours (ASCII r)
b Timer S4 parallel slalom: identification for blue parcours (ASCII b)
S Timer S4 speed: identification for speed measurement
§ Timer S4 speed: identification for measuring unit (01Hex=km/h, 02Hex=m/s, 03Hex=mph)
Z Timer S4 speed: speed
F Timer S4 swimming: address for ranking board A to H
(A = board 1, B = board 2, C = board 3, ..., H = board 8)

	1	2	3	4	5	6	7	8	9	10	11	12	13	14	15	16	17	18	19	20	21	22	23	24		
J Nh Nz Ne									H	H	:	M	M	:	S	S	.	z	h	t	Rz	Re	X		time for board 10	
J Nh Nz Ne									H	H	:	M	M	:	S	S	.							X	time for board 10	
Nh Nz Ne								H	H	:	M	M	:	S	S	.								X	running time	
Nh Nz Ne A								H	H	:	M	M	:	S	S	.	z	h	t	Rz	Re	X			intermediate time 1	
Nh Nz Ne B								H	H	:	M	M	:	S	S	.	z	h	t	Rz	Re	X			intermediate time 2	
Nh Nz Ne C								H	H	:	M	M	:	S	S	.	z	h	t	Rz	Re	X			run time	
Nh Nz Ne D								H	H	:	M	M	:	S	S	.	z	h	t	Rz	Re	X			total time	
Nh Nz Ne K Tc								Nt	H	H	:	M	M	:	S	S	.	z	h	t	X				run time	
Tt								H	H	:	M	M	:	S	S	.					X					Comet Stopwatch
Tt								H	H	:	M	M	:	S	S	.	z	h	t	X						Timer S4 / Split
Pr Tt								H	H	:	M	M	:	S	S	.	z	h	t	X						Timer S4 / Split
Pr Tt								H	H	:	M	M	:	S	S	.	z	h	t	X						Timer S4 / 3-Parcours
PZ PE								H	H	:	M	M	:	S	S	.	z	h	t	X						Timer S4 / 3-Parcours
PZ PE								H	H	:	M	M	:	S	S	.	z	h	t	X						Timer S4 / Show Jumping
#h #z #e								H	H	:	M	M	:	S	S	.	z	h	t	X						Timer S4 / Show Jumping
#h #z #e								H	H	:	M	M	:	S	S	.	z	h	t	X						Timer S4 / 18-Channel
Pp														r	:	S	z	h	t	X					Timer S4 / 18-Channel	
Pp														b	:	S	z	h	t	X					run time "red wins"	
Pp r								H	H	:	M	M	:	S	S	.	z	h	t	X						run time "blue wins"
Pp b								H	H	:	M	M	:	S	S	.	z	h	t	X						running time "red"
Pp r -														r	:	S	z	h	t	X					run time "blue"	
F														Z	:	Z	z	h	t	X					difference time, red win.	
F														M	:	S	S	.	z							speed
														M	:	S	S	.	z							running time (ranking)
														M	:	S	S	.	z	h						run time (ranking)
#h #z #e														M	:	S	S	.	z							running time (board 1)
#h #z #e														M	:	S	S	.	z	h	Re	X				run time (board 1)
#h #z #e														M	:	S	S	.	z							running time
#h #z #e														M	:	S	S	.	z	h	t	X				run time

8. DISPLAY FORMATS OF THE DISPLAY BOARD GAZ4

You can adjust the different display board configurations with the toggle switch (3) and thumb wheel switch (1).

The following examples base on the standard display board GAZ4 with 5 or 6 digit.

Minutes, Seconds, 1/100 Seconds:

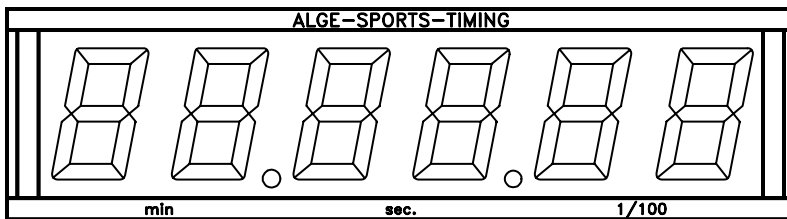

Hours, Minutes, Seconds:

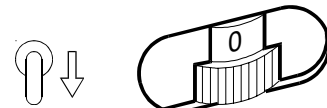
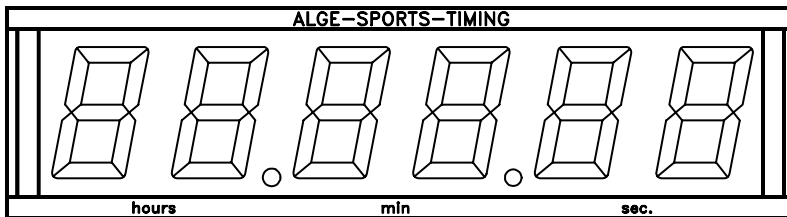

Hours, Minutes, Seconds, 1/10 Seconds:

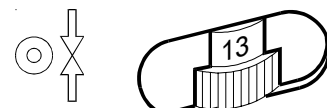
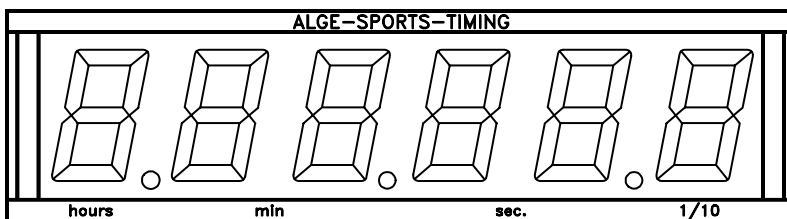

Minutes, Seconds, 1/1000 Seconds:

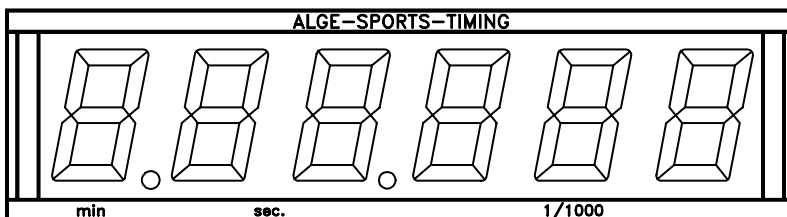

Start Number, Rank:

You can use a 5 or 6 digit board for this configuration. When using a 6 digit board it will show the 4th digit blank.

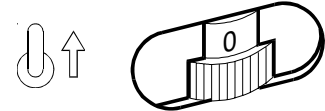
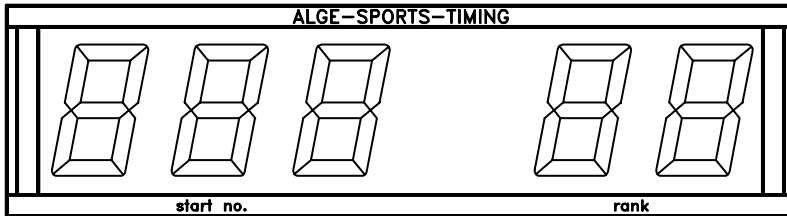

Counter (with Comet Program Commander):

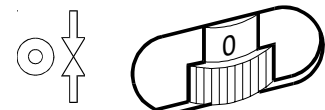
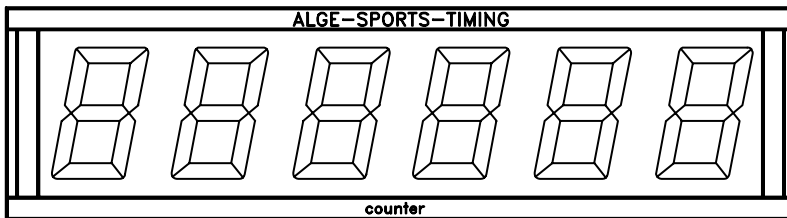

Speed:

Depending of the timer you can show the speed in km/h, m/s, or mph.

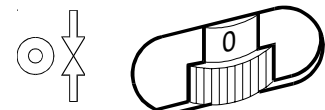
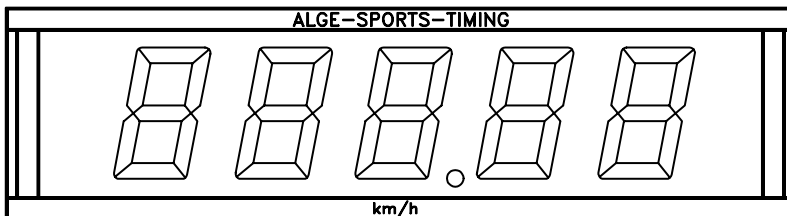

Points:

You can control the points form a Comet Commander, Timer S4 (show jumping) or PC.

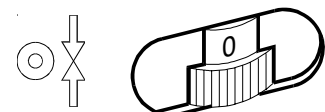
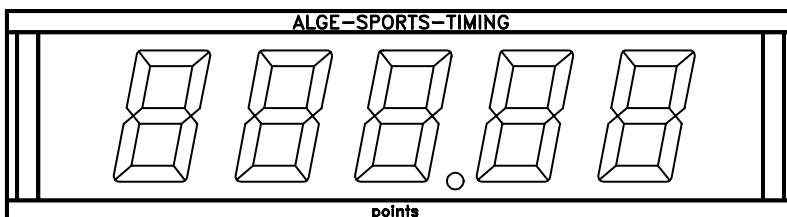

9. RANKING (LEADER) BOARD

What can you do with a ranking board?:

You can show up to 10 times on the display-boards together with the rank and startnumber. You can scroll up or down.

Use of the ranking board:

For events when you want to show the latest results to the spectators.

Necessary equipment for a ranking board:

- 1 ALGE Tdc 4000
- 1 Computer (PC with DOS)
- 1 Ranking board software
- X ALGE GAZ4 with startnumber/rank
- X ALGE GAZ4 with time
- 1 Power-supply NGAZ/R for all display boards
- 1 Cable reel KT300 or 2 wire cable
- 1 Magic 069-02 connection box
- X cable 033-01
- X cable 033-10

